

# MAGICVAC

THE ORIGINAL VACUUM SEALING SYSTEM

# GENERAL CATALOGUE



**HOUSEHOLD  
VACUUM SEALERS**

**PROFESSIONAL  
VACUUM SEALERS**

**BAGS AND ROLLS,  
CONTAINERS, ACCESSORIES**

# The invention of vacuum sealing.

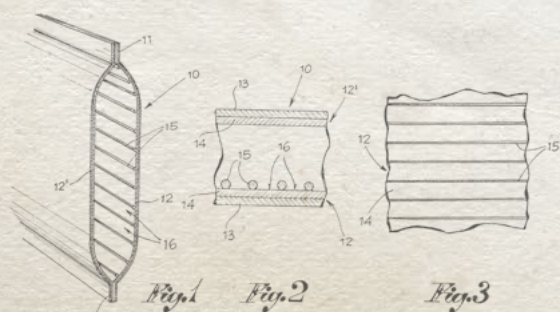
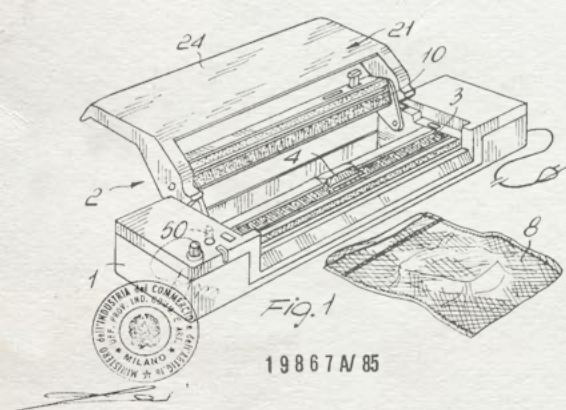

## 1985 the first vacuum sealer

There was a time when freshness was a fleeting luxury, a flavor to be enjoyed quickly. Then, in 1985, we had an idea: to use the know-how we had developed in the electromedical field to bring vacuum food preservation into everyone's home. Since then, we have constantly innovated and perfected our formula for preservation.

## 1990 the Magic Vac brand is born

Riding the wave of the success of the first machine, a brand entirely dedicated to vacuum sealing was launched: Magic Vac was officially born. The new brand immediately positioned itself as a specialist in freshness, with a promise of quality and innovation.

## 1995 the invention of the embossed bag

Magic Vac patents an innovative bag with a channel structure. This technology, featuring special grooves, proves to be the optimal solution for air removal, ensuring a high level of vacuum and even longer-lasting preservation.

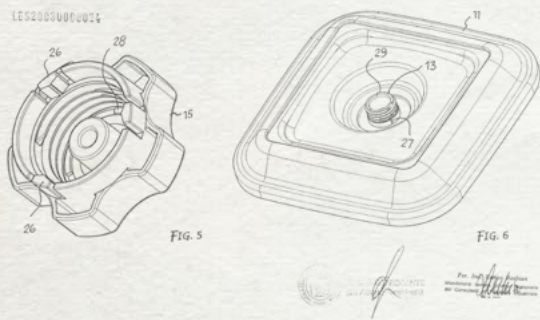

## 2004 the first vacuum container with a valve

The Magic Vac system expands with Executive containers. Their patented valve not only offers optimal protection for liquid and fragile foods, but also allows for the quick marinating function, expanding the possible uses of vacuum sealing.

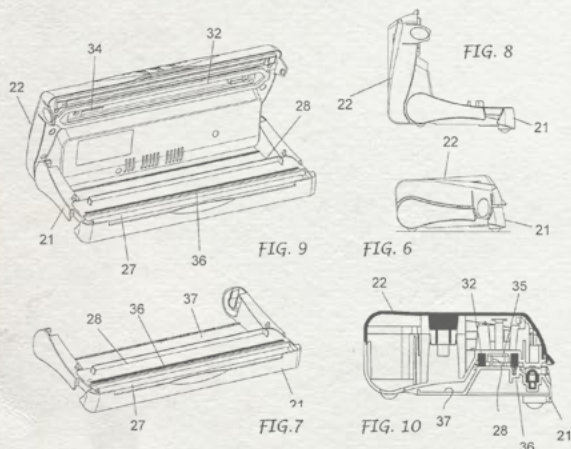

## 2008 the revolution of convenience

Futura is introduced, the first domestic vacuum sealer equipped with a removable and dishwasher-safe liquid-collecting tray. The goal is to improve the practicality of the machines by making cleaning easier.

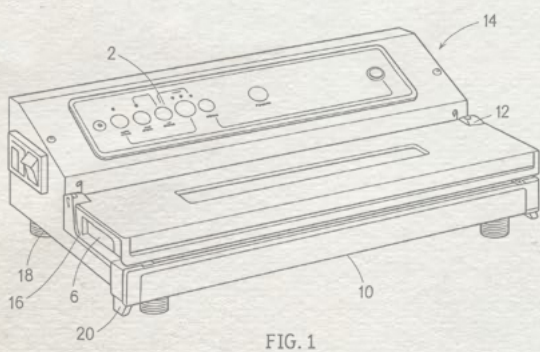

## 2010 the new professional line

After 25 years dedicated to domestic vacuum sealing, Magic Vac brings its know-how and new external extraction solutions to the professional world of food service and catering.

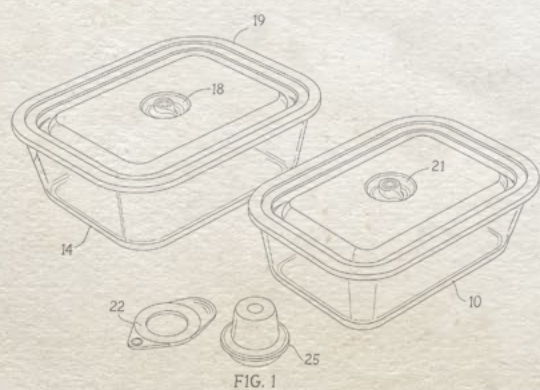

## 2022 Free is born, the glass pan for sous-vide cooking

Introducing "Free", a revolutionary glass pan for traditional and sous-vide cooking, marinating, and vacuum preservation. An extremely versatile and eco-friendly solution made of glass, steel, and silicone. Maximum freedom in the kitchen, the result of Magic Vac innovation.

# Why choose the original vacuum sealing system?



## Because we invented it.

Magic Vac was born in 1985 from the experience of Gruppo Flaem, an Italian manufacturing company founded in 1966 specializing in electromedical products. Our mission has always been to improve the quality of life with products rigorously controlled throughout the entire production cycle to ensure the maximum quality and reliability that have always distinguished us.

## Wide range of patented accessories.

Magic Vac is more than just a machine. We design and manufacture patented appliances, bags, and accessories that work in perfect synergy to guarantee maximum air/oxygen extraction and the promised result.

## Certified quality, not just a promise.

We use only non-toxic materials that comply with international directives for food contact, without the migration of harmful substances into food. We operate according to ISO 9001:2015 standards. The reliability of our products is verified by the most important international laboratories (TÜV Rheinland, Intertek) and by safety marks such as GS and cETLus.

## Tested preservation times.

The promise "freshness up to 5 times longer" is not a slogan, but a proven result. This is demonstrated by a "Parere Pro Veritate" analysis written exclusively for us by Prof. Luciano Piergiovanni of DISTAM, University of Milan, and member of AITA, the Italian Association of Food Technologies. The study attests to and certifies the superior preservation times achieved with the Magic Vac system.



## Order and hygiene

Vacuum sealing allows you to organize space in the fridge, freezer, and pantry, thanks to stackable and transparent bags and containers. Every food item is protected, guaranteeing ideal hygienic conditions and eliminating any risk of cross-contamination.



## Save time and money

Vacuum sealing is an investment that allows you to buy in bulk, preserve perfectly, meal prep for the week, and reduce waste. Bags and containers can be used for defrosting in the microwave for maximum convenience.



## Fresh food for longer

By eliminating oxygen, oxidation and the growth of microorganisms are blocked, keeping flavor, color, and nutritional properties intact. In the freezer, it also prevents freezer burn, protecting the texture and quality of food.



## Sous-Vide Cooking

Vacuum sealing is essential for sous-vide cooking. This method allows you to achieve incredibly tender meats, juicy fish that melts in your mouth, and vegetables with perfect consistency and flavor.

## Food preservation time chart (in days)

	REFRIGERATOR +5°C						FREEZER -18°C			PANTRY +25°C	
WITH MAGIC VAC® VACUUM	8 - 9	4 - 5	25 - 60	24 - 40	7 - 10	14 - 20	450 - 600	300 - 360	540 - 720	6 - 8	360
WITHOUT VACUUM	3 - 4	1 - 3	15 - 20	7 - 15	1 - 3	5 - 7	120 - 180	90 - 120	240 - 300	1 - 2	120 - 180



# HOUSEHOLD VACUUM SEALERS

8

# PROFESSIONAL VACUUM SEALERS

32

<b>BAGS AND ROLLS</b>	<b>46</b>
<b>CONTAINERS</b>	<b>50</b>
<b>ACCESSORIES</b>	<b>58</b>



# HOUSEHOLD VACUUM SEALERS

Every home has different habits, rhythms, and spaces. The domestic vacuum sealing range was created to meet every specific need, from that of a couple to a large family or a small business. Making vacuum preservation accessible to every situation is our mission.



## USAGE

■■■ INTENSIVE

■■■ FREQUENT

■■■ OCCASIONAL

## FEATURES



Double pump  
18L/min



Single pump  
10 to 12L/min



Single pump  
9L/min



Robust design



Versatile design



Compact design



For intensive users



For families



For couples and  
singles

## MODELS

Perfetta  
Maxima 2

Master  
Axolute  
Champion  
Activa  
Dinamika  
Genius  
Futura  
Alice

Elite 300 Plus  
Compact

# Perfetta

Vacuum sealing perfection.

The domestic vacuum sealer with digital control,  
equipped with a double pump of 18 L/min.



Made in Italy



Three sealing modes  
for dry, humid, and very  
humid foods



Double pump  
18 L/min



Innovative vacuum  
level presetting



Professional 30cm  
sealing bar in aluminum



Actiseal 3D technology  
for precise sealing

Code > V272PK1 | Color > Silver/Black | Pack > 2 pcs | EAN > 8018294014001

# HOUSEHOLD VACUUM SEALER / INTENSIVE USE ■■■



## \*\*\* Removable liquid-collecting tray

The liquid-collecting tray on Perfetta captures excess liquids during vacuuming. It is removable and dishwasher-safe, ensuring maximum hygiene and keeping the machine perfectly clean.



## 12<sup>min</sup> Quick marinating function

The Marinating function of Perfetta, combined with the special Magic Vac canisters, alternates vacuum and rest cycles, helping to open the food fibers for an intense flavor in just 12 minutes instead of several hours.

1  
**VACUUM & SEAL**  
Automatic cycle vacuum + bag sealing

4  
**SEAL**  
Instant manual sealing

2  
**VACUUM PULSE**  
Pulse vacuum function for delicate foods

5  
**SEALING MODE**  
Sealing time adjustment (Dry/Humid)

3  
**CANISTER**  
Automatic vacuum cycle for containers

6  
**MARINATING**  
Quick marinating function in just 12 minutes

Usable with rolls and bags > ✓ 15 cm ✓ 20 cm ✓ 30 cm | (LxWxH): 51 x 17.5 x 10.5 cm 3.25 Kg

Included Accessories >



1 roll 30x300cm  
5 bags 20x30cm



Connection tube for accessories



Bag cutter

Certifications >



# Maxima 2

The ultimate solution for cooks  
and aspiring chefs.

The household vacuum sealing machine with semi-professional  
performance, equipped with a double pump of 18 L/min.



Made in Italy



Three sealing modes  
for dry, humid, and very  
humid foods



Double pump  
18 L/min



Actiseal 3D technology  
for precise sealing



Professional 30cm  
sealing bar in  
aluminum



Hygienic roll-holder  
compartment with  
built-in bag cutter and  
protection cover

Code > VD50PK2 | Color > Black-silver + Chrome Inserts | Pack > 3 pcs | EAN > 8018294010843

# HOUSEHOLD VACUUM SEALER / INTENSIVE USE ■■■



## LED-illuminated look-in window

The practical LED-illuminated look-in window on Maxima 2 allows you to check the correct bag placement, ensuring it is positioned perfectly for optimal vacuum and sealing performance.

## 12<sup>min</sup> Quick marinating function

The Marinating function of Maxima 2, combined with the special Magic Vac canisters, alternates vacuum and rest cycles, helping to open the food fibers for an intense flavor in just 12 minutes instead of several hours.

<p>1</p> <p><b>PULSE</b> Pulse Vacuum function</p>	<p>2</p> <p><b>CANISTER</b> Function for creating vacuum in containers</p>	<p>3</p> <p><b>MARINATING</b> Quick marinating function in 12 minutes</p>
<p>4</p> <p><b>PUMP SPEED</b> Pump speed regulation</p>	<p>5</p> <p><b>SEALING MODE</b> Sealing time regulation (dry, humid, and very humid food)</p>	<p>6</p> <p><b>DIGITAL LED</b> Vacuum cycle indicator</p>



Usable with rolls and bags >  15 cm  20 cm  30 cm | (LxWxH): 44 x 24 x 11 cm  4 Kg

### Included Accessories >



1 roll 30x300cm  
5 bags 20x30cm



Connection tube for accessories



Bag cutter

### Certifications >



# Master

Food freshness, mastered.

The domestic vacuum sealer with a precise analog vacuum gauge, equipped with a single pump of 10 L/min.



Made in Italy

30



Professional 30 cm aluminum sealing bar



Analog vacuum gauge to control the vacuum level reached



Completely removable liquid-collecting tray



Pulse vacuum function for delicate foods



Convenient roll-holder compartment and bag cutter

Code › V252PK1 | Color › White | Pack › 3 pcs | EAN › 8018294014230

## HOUSEHOLD VACUUM SEALER / FREQUENT USE ■■■



### Pulse vacuum function

The Pulse vacuum function of Master allows manual control of the vacuum level. The user can extract air in small and repeated intervals to avoid crushing or damaging fragile and delicate foods.



### Canister vacuum function

The Canister function of Master allows air to be extracted from the dedicated containers using the accessory hose connected to the machine, significantly extending the shelf life of delicate, liquid, and semi-liquid foods.

<p>1</p> <p><b>VACUUM &amp; SEAL</b> Automatic cycle vacuum + bag sealing</p>	<p>4</p> <p><b>SEAL</b> Manual sealing</p>
<p>2</p> <p><b>VACUUM PULSE</b> Pulse vacuum function</p>	<p>5</p> <p><b>SEALING MODE</b> Sealing time adjustment</p>
<p>3</p> <p><b>CANISTER</b> Automatic vacuum cycle for containers</p>	<p>6</p> <p><b>CANCEL</b> Cancels all functions</p>

Usable with rolls and bags >  15 cm  20 cm  30 cm | (LxWxH): 51 x 17.5 x 10.5 cm 3 Kg

#### Included Accessories >



1 roll 30x30cm  
5 bags 20x30cm



Connection tube for accessories



Wall mounting kit

#### Certifications >



# Axolute

**Absolute prestige.**

The domestic vacuum sealing machine with an exclusive design,  
equipped with a single pump of 10 L/min.



Made in Italy



Pulse vacuum  
function for delicate  
foods



Single pump 10L/min



Hygienic roll-holder  
compartment with  
built-in bag cutter and  
protection cover

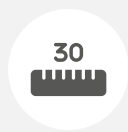

Professional 30cm  
sealing bar in aluminum



Actiseal 3D technology  
for precise seals

Code › VD04PK1 | Color › White + Chrome Inserts | Pack › 3 pcs | EAN › 8018294010881

# HOUSEHOLD VACUUM SEALER / FREQUENT USE ■■■



## LED-illuminated look-in window

The practical LED-illuminated look-in window on Axolute allows you to check the correct bag placement, ensuring it is positioned perfectly for optimal vacuum and sealing performance.

## Canister vacuum function

The Canister function of Axolute allows air to be extracted from the dedicated containers using the accessory hose connected to the machine, significantly extending the shelf life of delicate, liquid, and semi-liquid foods.

<p>1</p> <p><b>PULSE</b> Pulse vacuum function</p>	<p>2</p> <p><b>CANISTER</b> Function for creating vacuum in containers</p>	<p>3</p> <p><b>SEAL</b> Manual sealing function</p>
<p>4</p> <p><b>PUMP SPEED</b> Pump speed regulation</p>	<p>5</p> <p><b>SEALING MODE</b> Sealing time regulation (dry and humid food)</p>	<p>6</p> <p><b>DIGITAL LED</b> Vacuum cycle indicator</p>

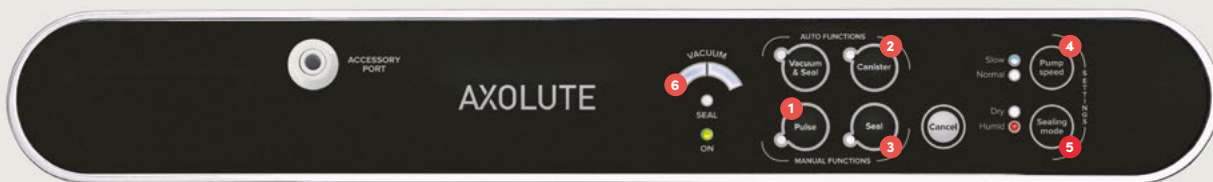

Usable with rolls and bags > ✓ 15 cm ✓ 20 cm ✓ 30 cm | (LxWxH): 44 x 24 x 11 cm 3.8 Kg

### Included Accessories >



1 roll 30x300cm  
5 bags 20x30cm



Connection tube for accessories



Bag cutter

### Certifications >



# Champion

A true Champion among vacuum sealers.

The simple and intuitive domestic vacuum sealing machine, equipped with a single pump of 10 L/min.



Made in Italy



Two sealing modes for dry and humid foods



Single pump 10 L/min



Waterproof multifunction panel

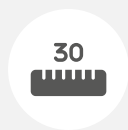

Professional 30cm sealing bar in aluminum



Roll storage compartment with integrated bag cutter

Code › V212PK1 | Color › White + Black | Pack › 3 pcs | EAN › 8018294013998

# HOUSEHOLD VACUUM SEALER / FREQUENT USE ■■■



## Removable liquid-collecting tray

The liquid-collecting tray on Champion captures excess liquids during vacuuming. It is removable and dishwasher-safe, ensuring maximum hygiene and keeping the machine perfectly clean.



## Canister vacuum function

The Canister function of Champion allows air to be extracted from the dedicated containers using the accessory hose connected to the machine, significantly extending the shelf life of delicate, liquid, and semi-liquid foods.

1	4
<b>VACUUM &amp; SEAL</b> Automatic vacuum + bag sealing cycle	<b>SEAL</b> Manual sealing
2	5
<b>VACUUM PULSE</b> Pulse vacuum function	<b>SEALING MODE</b> Sealing time regulation
3	6
<b>CANISTER</b> Automatic vacuum cycle for containers	<b>CANCEL</b> Cancels all functions

Usable with rolls and bags >



15 cm



20 cm



30 cm



(LxWxH): 51 x 17.5 x 10.5 cm



3 Kg

Included Accessories >



1 roll 30x300cm  
5 bags 20x30cm



Connection tube for accessories

Certifications >



# Activa

All vacuum functions, activated.

The domestic vacuum sealing machine with a minimalist design, equipped with a single pump of 12 L/min.



Italian Design



Two sealing modes for dry and humid foods



Single pump  
12 L/min



Two vacuum-speed regulation levels



Intuitive lock and unlock system



Roll storage compartment with integrated bag cutter

Code > VL02PK1 | Color > White + Black | Pack > 4 pcs | EAN > 8018294017439

# HOUSEHOLD VACUUM SEALER / FREQUENT USE



## LED-illuminated look-in window

The practical LED-illuminated look-in window on Activa, not only lets you check the correct bag placement, but also lights up in two colors: blue during vacuuming and red during sealing.

## 12<sup>min</sup> Quick marinating function

The Marinating function of Activa, combined with the special Magic Vac canisters, alternates vacuum and rest cycles, helping to open the food fibers for an intense flavor in just 12 minutes instead of several hours.

<p>1</p> <p><b>SLOW // NORMAL</b> Sets the pump vacuum speed (slow/normal)</p>	<p>2</p> <p><b>DRY // HUMID</b> Sets the seal for dry or humid foods</p>	<p>3</p> <p><b>VACUUM &amp; SEAL // CANCEL</b> Starts vacuum with sealing, stopping other actions</p>
<p>4</p> <p><b>PULSE &amp; CANISTER</b> Ideal for vacuum sealing fragile foods in bags and containers</p>	<p>5</p> <p><b>MARINATE</b> Starts the quick marinating cycle</p>	<p>6</p> <p><b>MANUAL SEAL</b> Starts the manual bag sealing</p>

Usable with rolls and bags > ✓ 15 cm ✓ 20 cm ✓ 30 cm | (LxWxH): 41.5 x 19.5 x 11.2 cm 2.25 Kg

### Included Accessories >



### Certifications >

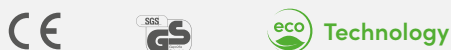

# Dinamika

Versatility, perfectly sealed.

The domestic vacuum sealer with a modern design,  
equipped with a single pump of 12 L/min.



Italian Design



Two sealing modes  
for dry and humid foods



Single pump  
12 L/min



Two vacuum-speed  
regulation levels



Intuitive lock  
and unlock system



Roll storage  
compartment with  
integrated bag cutter

Code › VG02PK1 | Color › White + Silver | Pack › 4 pcs | EAN › 8018294010874

# HOUSEHOLD VACUUM SEALER / FREQUENT USE ■■■



## Pulse vacuum function

The pulse vacuum function of Dinamika allows manual control of the vacuum level. The user can extract air in small, repeated intervals to prevent crushing or damaging fragile and delicate foods.



12<sup>min</sup>

## Quick marinating function

The Marinating function of Dinamika, combined with the special Magic Vac canisters, alternates vacuum and rest cycles, helping to open the food fibers for an intense flavor in just 12 minutes instead of several hours.

<p>1</p> <p><b>SLOW // NORMAL</b> Sets the pump vacuum speed (slow/normal)</p>	<p>2</p> <p><b>DRY // HUMID</b> Sets the seal for dry or humid foods</p>	<p>3</p> <p><b>VACUUM &amp; SEAL // CANCEL</b> Starts vacuum with sealing, stopping other actions</p>
<p>4</p> <p><b>PULSE &amp; CANISTER</b> Ideal for vacuum sealing fragile foods in bags and containers</p>	<p>5</p> <p><b>MARINATING</b> Starts the quick marinating cycle</p>	<p>6</p> <p><b>MANUAL SEAL</b> Starts the manual bag sealing</p>



Usable with rolls and bags > ✓ 15 cm ✓ 20 cm ✓ 30 cm | (LxWxH): 45.5 x 23.2 x 11.9 cm ⚖️ 2.3 Kg

Included Accessories >



1 roll 30x300 cm



Connection tube for accessories

Certifications >



# Genius

Simple, smart vacuum sealing.

The robust and intuitive domestic vacuum sealer,  
equipped with a single pump of 10 L/min.



Made in Italy



Multifunction button  
to start or stop the  
automatic/manual cycle



Single pump  
10 L/min



Multicolored LED  
indicator for power-on,  
vacuum, and sealing



Professional  
30 cm sealing bar



The most powerful  
motor in its category



SILVER/RED  
EDITION

Code › V402PK2 | Col. › White | Pack › 4 pcs | EAN › 8018294007348  
Code › V402PK3 | Col. › Silver/Red | Pack › 4 pcs | EAN › 8018294007447

# HOUSEHOLD VACUUM SEALER / FREQUENT USE



## Large liquid-collecting tray

The liquid-collecting tray of Genius is designed to collect any excess liquids during the vacuum cycle.



## Canister vacuum function

The canister function of Genius allows air to be extracted from the dedicated containers using the accessory hose connected to the machine, significantly extending the shelf life of delicate, liquid, and semi-liquid foods.



Usable with rolls and bags >



15 cm



20 cm



30 cm



(LxWxH): 39 x 14 x 10 cm



3.15 Kg

Included Accessories >



5 bags 20x30 cm



Connection tube for accessories



Bag cutter

Certifications >



# Futura

Give your food a future.

The elegant and easy-to-use domestic vacuum sealer, equipped with a single pump of 10 L/min.



Made in Italy



Manual cycle for delicate foods



Single pump  
10 L/min



LED indicator for sealing in progress

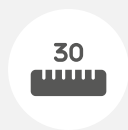

Professional  
30 cm sealing bar



Convenient silicone release button

Code › VB02PK1 | Color › Silver-Black | Pack › 4 pcs | EAN › 8018294007515

# HOUSEHOLD VACUUM SEALER / FREQUENT USE ■■■



## Removable liquid-collecting tray

The liquid-collecting tray on Futura captures excess liquids during vacuuming. It is removable and dishwasher-safe, ensuring maximum hygiene and keeping the machine perfectly clean.



## Canister vacuum function

The Canister function of Futura allows air to be extracted from the dedicated containers using the accessory hose connected to the machine, significantly extending the shelf life of delicate, liquid, and semi-liquid foods.



Usable with rolls and bags >

✓ 15 cm

✓ 20 cm

✓ 30 cm

(LxWxH): 39 x 14 x 8 cm

2.3 Kg

Included Accessories >



5 bags 20x30 cm



Connection tube for accessories



Bag cutter

Certifications >



# Alice

The wonderland of vacuum sealing.

The extremely easy-to-use domestic vacuum sealer,  
equipped with a single pump of 10 L/min.



Made in Italy



Manual cycle  
for delicate foods



Single pump  
10 L/min



LED indicator  
for sealing in progress

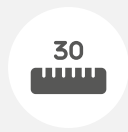

Professional  
30 cm sealing bar



Convenient silicone  
release button

Code › V952PK1 | Color › White | Pack › 4 pcs | EAN › 8018294006679

# HOUSEHOLD VACUUM SEALER / FREQUENT USE ■■■



## Large liquid-collecting tray

The liquid-collecting tray of Alice is designed to collect any excess liquids during the vacuum cycle.



## Canister vacuum function

The canister function of Alice allows air to be extracted from the dedicated containers using the accessory hose connected to the machine, significantly extending the shelf life of delicate, liquid, and semi-liquid foods.



Usable with rolls and bags >

✓ 15 cm

✓ 20 cm

✓ 30 cm



(LxWxH): 39 x 14 x 9 cm



2.3 Kg

Included Accessories >



5 bags 20x30 cm



Connection tube for accessories



Bag cutter

Certifications >



# Elite 300 Plus

Where performance meets elegance.

The domestic vacuum sealer with a refined design,  
equipped with a single pump of 9 L/min.



Made in Italy



Manual cycle  
for delicate foods



Single pump  
9 L/min



LED indicator  
for sealing in progress



Professional  
30 cm sealing bar



Convenient silicone  
release button

Code > VE52PK1 | Col. > White | Pack > 6 pcs | EAN > 8018294010614  
Code > VE59PK1 | Col. > Black | Pack > 6 pcs | EAN > 8018294012885



**BLACK  
EDITION**

# HOUSEHOLD VACUUM SEALER / OCCASIONAL USE



## Large liquid-collecting tray

The liquid-collecting tray of Elite 300 Plus is designed to collect any excess liquids during the vacuum cycle.



## Canister vacuum function

The canister function of Elite 300 Plus allows air to be extracted from the dedicated containers using the accessory hose connected to the machine, significantly extending the shelf life of delicate, liquid, and semi-liquid foods.



Usable with rolls and bags >  15 cm  20 cm  30 cm | (LxWxH): 38.7 x 11.5 x 9.6 cm 1.7 Kg

Included Accessories >



5 bags 20x30 cm



Connection tube for accessories



Bag cutter

Certifications >



# Compact

Compact size, powerful performance.

The domestic vacuum sealer with a compact design,  
equipped with a single pump of 9 L/min.



Italian design



Two sealing modes  
for dry and humid foods



Single pump  
9 L/min



5-LED indicator for  
vacuum cycle progress



Professional  
30 cm sealing bar



Convenient integrated  
bidirectional bag cutter

Code › VK02PK1 | Color › Black | Pack › 6 pcs | EAN › 8018294014797

# HOUSEHOLD VACUUM SEALER / OCCASIONAL USE ■■■



## Patented look-in window

The look-in window on Compact, allows you to check the correct bag placement, ensuring it is positioned perfectly for optimal vacuum and sealing performance.



## Canister vacuum function

The Canister function of Compact allows air to be extracted from the dedicated containers using the accessory hose connected to the machine, significantly extending the shelf life of delicate, liquid, and semi-liquid foods.

1

**HUMID**

Sets the sealing mode for humid foods

2

**DRY**

Sets the sealing mode for dry foods

3

**SEAL MODE**

Allows selection of DRY and HUMID

4

**SEAL**

Starts manual sealing of bags

5

**VAC SEAL**

Starts vacuum with sealing

6

**STOP**

Stops all functions in progress

Usable with rolls and bags > ✓ 15 cm ✓ 20 cm ✓ 30 cm | (LxWxH): 38 x 10 x 6 cm ⚖️ 0.94 Kg

### Included Accessories >



5 bags 20x30 cm





Connection tube for accessories





### Certifications >



INTENSIVE USE

MODEL	CODE	VACUUM SUCTION	SEALING TIME	ACTISEAL 3D	VACUUM LEVEL INDICATOR	LOCK & UNLOCK SYSTEM	VIEWING WINDOW
<b>Perfetta</b> 	V272PK1	Automatic	Adjustable (3 levels)	✓	Digital vacuum gauge 7 LED	-	✓
<b>Maxima 2</b> 	VD50PK2	Automatic (2 speed)	Adjustable (3 levels)	✓	Digital vacuum gauge 4 LED	✓	✓

FREQUENT USE

<b>Master</b> 	V252PK1	Automatic	Adjustable (2 levels)	-	Analog vacuum gauge	-	✓
<b>Axolute</b> 	VD04PK1	Automatic (2 speed)	Adjustable (2 levels)	✓	Digital vacuum gauge 2 LED	✓	✓
<b>Champion</b> 	V212PK1	Automatic	Adjustable (2 levels)	-	LED	✓	✓
<b>Activa</b> 	VL02PK1	Automatic (2 speed)	Adjustable (2 levels)	-	LED	✓	✓
<b>Dinamika</b> 	VG02PK1	Automatic (2 speed)	Adjustable (2 levels)	-	LED	✓	-
<b>Genius</b> 	V402PK2	Automatic	Fixed	-	LED	-	-
<b>Futura</b> 	VB02PK1	Automatic	Fixed	-	LED	-	-
<b>Alice</b> 	V952PK1	Automatic	Fixed	-	LED	-	-

OCCASIONAL USE

<b>Elite 300 Plus</b> 	VE59PK1 (black) VE52PK1 (white)	Automatic	Fixed	-	LED	-	-
<b>Compact</b> 	VK02PK1	Automatic	Adjustable (2 levels)	-	LED	✓	✓

MARINATING CYCLE	PULSE FUNCTION	REMOVABLE DRIP TRAY	ROLL HOLDER	PUMP TYPE	PUMP FLOW RATE (APPROX.)	VACUUM LEVEL (APPROX.)	MAX POWER
✓	✓	✓	✓	Double pump	18 L/min	(61 cm/Hg) - 0.80 bar	130 W
✓	✓	✓	✓	Double pump	18 L/min	(61 cm/Hg) - 0.80 bar	130 W
-	✓	✓	✓	Single pump	10 L/min	(60 cm/Hg) - 0.80 bar	130 W
-	✓	✓	✓	Single pump	10 L/min	(60 cm/Hg) - 0.80 bar	130 W
-	✓	✓	✓	Single pump	10 L/min	(60 cm/Hg) - 0.80 bar	140 W
✓	✓	✓	✓	Single pump	12 L/min	(60 cm/Hg) - 0.80 bar	130 W
✓	✓	-	✓	Single pump	12 L/min	(60 cm/Hg) - 0.80 bar	130 W
-	-	-	-	Single pump	10 L/min	(60 cm/Hg) - 0.80 bar	300 W
-	-	-	-	Single pump	10 L/min	(60 cm/Hg) - 0.80 bar	140 W
-	-	-	-	Single pump	10 L/min	(60 cm/Hg) - 0.80 bar	140 W
-	-	✓	-	Single pump	9 L/min	(59 cm/Hg) - 0.80 bar	140 W
-	-	-	-	Single pump	9 L/min	(56 cm/Hg) -0.78 bar	110 W



# PROFESSIONAL VACUUM SEALERS

The Magic Vac professional range is designed to meet the needs of professionals who use vacuum sealing as a work tool. The range is distinguished by its solid steel structure, high performance, and innovative removable lever, which simplifies cleaning.



USE

■■■ CONTINUOUS

■■■ VERY INTENSIVE

■■■ INTENSIVE

FEATURES



Double pump  
31.5 L/min



Double pump  
28 L/min



Double pump  
18 L/min



Robust stainless  
steel design



Compact stainless  
steel design



Compact stainless  
steel design



For large commercial  
activities



For professional  
users



For small  
businesses

MODELS

Jumbo 40  
Jumbo 40 Plus

Jumbo 30 Premium

Jumbo 30  
Jumbo 30 Evo

# Jumbo 40

Chef-sized vacuum sealer.

The professional vacuum sealing machine with an oversized sealing bar, equipped with a double pump of 31.5 L/min.



Made in Italy



Three sealing modes for dry, humid, and very humid foods



Double pump 31.5 L/min



Removable and dishwasher-safe liquid-collecting tray



Professional 40cm sealing bar with cooling system



Analog vacuum gauge

**JUMBO 40** Code > V706PK1  
Material > Stainless steel + ABS  
Pack > 1 pcs  
EAN > 8018294017842

**JUMBO 40 PLUS** Code > V718PK1  
Material > Stainless steel + ABS  
Pack > 1 pcs  
EAN > 8018294017859



Jumbo 40 Plus

# PROFESSIONAL VACUUM SEALER / CONTINUOUS USE ■■■



## Removable lever with integrated window

The upper lever of Jumbo 40 is completely removable to allow for complete, easy, and fast cleaning. The look-in window allows you to check the correct bag position for a perfect vacuum and seal.



## 12<sup>min</sup> Quick Marinating function

The Marinating function of Jumbo 40, combined with the special Magic Vac canisters, alternates vacuum and rest cycles, helping to open the food fibers for an intense flavor in just 12 minutes instead of several hours.

1

Fully automatic cycle (vacuums and seals automatically)

2

Manual cycle, the machine extracts the air until the S button is pressed

3

Manual sealing, recommended for preserving fragile foods

4

Three-level settings of sealing time (very useful for humid foods)

5

Canister function (vacuum for containers)

6

Quick marinating function



Usable with rolls > and bags



15 cm



20 cm



30 cm



40 cm



(LxWxH): 51 x 32 x 18.5 cm



9.5 kg

Included Accessories >



5 bags 40x50 cm



Connection tube for accessories



Bag cutter

Certifications >



# Jumbo 30 Premium

Maximum control.

The professional vacuum sealer with an innovative vacuum level pre-selector and equipped with a double pump of 28 L/min.



Made in Italy



Three sealing modes for dry, humid, and very humid foods



Double pump 28 L/min



Removable and dishwasher-safe liquid-collecting tray



Professional 30cm sealing bar with cooling system



Innovative vacuum level pre-setting

Code › V792PK1 | Material › Stainless steel + ABS | Pack › 1 pcs | EAN › 8018294013950

# PROFESSIONAL VACUUM SEALER / VERY INTENSIVE USE ■■■



## Greater control over the vacuum

The digital vacuum gauge of Jumbo 30 Premium offers maximum precision and control over the vacuum. This function allows you to pre-set the desired maximum vacuum level to protect the integrity of fragile and delicate foods.

## 12<sup>min</sup> Quick Marinating function

The Marinating function of Jumbo 30 Premium, combined with the special Magic Vac canisters, alternates vacuum and rest cycles, helping to open the food fibers for an intense flavor in just 12 minutes instead of several hours.

1

Fully automatic cycle (vacuums and seals automatically)

2

Manual cycle, the machine extracts the air until the S button is pressed

3

Manual sealing, recommended for preserving fragile foods

4

Three-level settings of sealing time (very useful for humid foods)

5

Canister function (vacuum for containers)

6

Quick marinating function



Usable with rolls and bags >

15 cm

20 cm

30 cm



(LxWxH): 41.5 x 24.5 x 12.5 cm



5 Kg

Included Accessories >



5 bags 30x40 cm



Connection tube for accessories



Bag cutter

Certifications >



# Jumbo 30 Evo

Professional vacuum, in plain sight.

The professional vacuum sealing machine with a vacuum level indicator, equipped with a double pump of 18 L/min.



Made in Italy



Three sealing modes for dry, humid, and very humid foods



Double pump 18 L/min



Removable and dishwasher-safe liquid-collecting tray



Professional 30cm sealing bar with cooling system



Analog vacuum level gauge

Code › V772PK2 | Material › Stainless steel + ABS | Pack › 1 pcs | EAN › 8018294012182

# PROFESSIONAL VACUUM SEALER / INTENSIVE USE ■■■



## ★ Patented transparent window

The practical look-in window of Jumbo 30 Evo allows you to check the correct bag placement, ensuring it is in the optimal position for a perfect vacuum and seal.

## 12<sup>min</sup> Quick Marinating function

The Marinating function of Jumbo 30 Evo, combined with the special Magic Vac canisters, alternates vacuum and rest cycles, helping to open the food fibers for an intense flavor in just 12 minutes instead of several hours.

1

Fully automatic cycle (vacuums and seals automatically)

2

Manual cycle, the machine extracts the air while the button is pressed

3

Manual sealing, recommended for preserving fragile foods

4

Three-level settings of sealing time (very useful for humid foods)

5

Canister function (vacuum for containers)

6

Quick marinating function



Usable with rolls and bags >



15 cm



20 cm



30 cm



(LxWxH): 41.5 x 24.5 x 12.5 cm



5 Kg

Included Accessories >



5 bags 30x40 cm



Connection tube for accessories



Bag cutter

Certifications >



# Jumbo 30

A great start for every professional.

The robust and compact professional vacuum sealing machine, equipped with a double pump of 18L/min.



Made in Italy



Three sealing modes for dry, humid, and very humid foods



Double pump 18 L/min



Canister function (vacuum in containers)

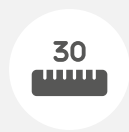

Professional 30cm sealing bar with cooling system



Quick Lock & Unlock closing system

Code > V752PK1 | Material > Stainless steel + ABS | Pack > 1 pcs | EAN > 8018294011383



### Professional sealing bar

The 30 cm professional sealing bar of Jumbo 30, with a powerful double pump, ensures flawless and rapid seals. Advanced functions like ActiSeal 3D guarantee total control of the seal on any food.



### Removable liquid-collecting tray

The liquid-collecting tray of Jumbo 30 collects any excess liquids during the vacuum process. It is completely removable and dishwasher-safe, guaranteeing maximum hygiene and machine cleanliness.

1

Fully automatic cycle (vacuums and seals automatically)

2

Manual cycle, the machine extracts the air while the button is pressed

3

Manual sealing, recommended for preserving fragile foods in bags

4

Three-level settings of sealing time (very useful for humid foods)

5

Canister function (vacuum for containers)



Usable with rolls and bags >



15 cm



20 cm



30 cm



(LxWxH): 41.5 x 24.5 x 12.5 cm



5 Kg

Included Accessories >



5 bags 30x40 cm



Connection tube for accessories





Bag cutter

Certifications >





CONTINUOUS USE

MODEL	CODE	VACUUM SUCTION	SEALING TIME	ACTISEAL 3D	VACUUM LEVEL INDICATOR	LOCK & UNLOCK SYSTEM	VIEWING WINDOW
<b>Jumbo 40</b> 	V706PK1	Automatic	Adjustable (3 levels)	✓	✓	✓	✓
<b>Jumbo 40 Plus</b> 	V718PK1	Automatic	Adjustable (3 levels)	✓	✓	✓	✓

VERY INTENSIVE USE

<b>Jumbo 30 Premium</b> 	V792PK1	Adjustable (8 levels)	Adjustable (3 levels)	✓	✓	✓	✓
--	---------	-----------------------	-----------------------	---	---	---	---

INTENSIVE USE

<b>Jumbo 30 Evo</b> 	V772PK2	Automatic	Adjustable (3 levels)	✓	✓	✓	✓
<b>Jumbo 30</b> 	V752PK1	Automatic	Adjustable (3 levels)	✓	-	✓	✓

MARINATING CYCLE	PULSE FUNCTION	REMOVABLE DRIP TRAY	ROLL HOLDER	PUMP TYPE	PUMP FLOW RATE (APPROX.)	VACUUM LEVEL (APPROX.)	MAX POWER
✓	✓	✓	-	Double pump	31.5 L/min	- 0.85 bar	380 W
✓	✓	✓	✓	Double pump	31.5 L/min	- 0.85 bar	380 W
✓	✓	✓	-	Double pump	28 L/min	- 0.83 bar	130 W
✓	✓	✓	-	Double pump	18 L/min	- 0.80 bar	130 W
-	✓	✓	-	Double pump	18 L/min	- 0.80 bar	130 W



# BAGS AND ROLLS, CONTAINERS, ACCESSORIES

The excellence of the Magic Vac system extends to the entire range of accessories, designed to offer maximum versatility in the kitchen. Made with non-toxic materials and patented technologies, our bags, rolls, and containers work in perfect synergy with the machines. It is this combination that guarantees maximum performance and ensures the promised result.



TYPE

BAGS AND ROLLS

CONTAINERS

ACCESSORIES

FEATURES



Multilayer channeled structure



Space-saving design



Maximum practicality



Safe materials



Patented technologies



Extremely versatile



Ideal for sous-vide



High-quality materials



Home and Kitchen organization

VARIANTS

Channeled bags with or without pre-printed label

Channeled rolls with or without pre-printed label

Free Line  
Executive Line  
Family Line  
Gastronorm Line

Bottle cup  
Bag cutter  
Accessories for glass jars  
Space-saving bags  
SpaceOff



# Bags and Rolls

The guarantee of a perfect vacuum.

The patented ribbed structure and superior thickness (240µm) guarantee maximum air removal and perfect preservation.



Made in Italy



Total protection from odours and humidity



Maximum air removal



Reusable



Puncture resistant



BPA and phthalate free

## Tested and certified for boiling and sous-vide cooking

Magic Vac bags and rolls are tested and certified to withstand Sous-Vide cooking temperatures. Made with multilayer materials free of BPA and phthalates, they guarantee safe and healthy cooking, preserving the flavors and nutritional properties of food.



🕒 1h: 100° C    🕒 8h: 90° C    🕒 72h: 70° C

## Bags and rolls with pre-printed label

The practical label allows you to easily note the date and content, facilitating the organization and management of supplies in the pantry, fridge, or freezer. An ideal solution for those who want to keep their preparations under control.



### CHANNELED BAGS

CODE	QTY	SIZE	PACK
ACO1076	100	20x30 cm	14 pcs
ACO1059	50	20x30 cm	28 pcs
ACO1061	20	20x30 cm	60 pcs
ACO1129	50	25x35 cm	14 pcs
ACO1064	50	30x40 cm	12 pcs

### CHANNELED ROLLS

CODE	QTY	SIZE	PACK
ACO1068	2	30x600 cm	20 pcs
ACO1066	2	20x600 cm	30 pcs
ACO1075	4	15x600 cm	20 pcs

### CHANNELED BAGS WITH LABEL

CODE	QTY	SIZE	PACK
ACO1040	100	20x30 cm	14 pcs
ACO1024	50	20x30 cm	28 pcs
ACO1036	50	30x40 cm	12 pcs

### CHANNELED ROLLS WITH LABEL

CODE	QTY	SIZE	PACK
ACO1025	2	30x600 cm	20 pcs
ACO1026	2	20x600 cm	30 pcs

# The first and original channeled bag

The patented channel technology delivers unmatched air extraction, protecting food from oxidation and keeping it fresh up to 5 times longer. The robust multilayer structure also prevents freezer burn and provides total protection from odours and humidity.

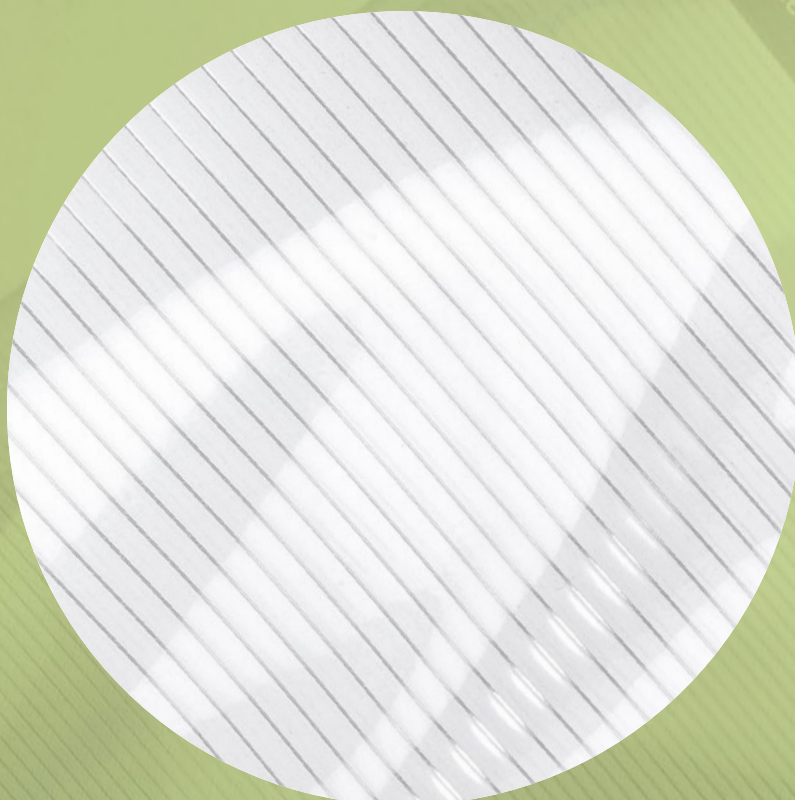

**MAGIC VAC**  
IL VERO SOTTOVUOTO  
— The original vacuum sealing system —





# Executive Line

Professional vacuum sealing for everyone.

Containers made with high-quality materials, with a three-position valve and a protective lid that prevents the suction of liquids.



Made in Italy



Extremely resistant structure



Suitable for use in the freezer



Liquid protection valve



Defrost in microwave without lid



BPA and phthalate free



**Replacement Executive Lids** ACO1074 (2.5L) - ACO1009 (1.5L-4L) - ACO1010 (2L)



### Square Executive Container

ACO1073 (2.5L)

Used with vacuum sealers equipped with the "Marinating" function, it allows you to flavor meat, fish, and vegetables in just 12 minutes by setting the valve to "Open (M)". Its stackable structure also ensures maximum storage convenience.

### Cylindrical Executive Containers

ACO1002 (4L) - ACO1003 (2L) - ACO1004 (1.5L)  
ACO1005 (4+2L)

Cylindrical Executive containers are available in various sizes to meet every need and are ideal for preserving delicate, liquid, and semi-liquid foods. The transparent design also ensures easy monitoring of food in the refrigerator.



### Universal Executive Lids

ACO1011 (Ø12.5cm) - ACO1012 (Ø10cm)

Bowls, cups, and jars can be turned into vacuum containers with a simple gesture. These universal lids adapt to different diameters and materials, sealing in the authentic freshness of food directly in the containers you already have in your kitchen.



# Family Line

Everyday vacuum sealing.

Practical and versatile, available in various sizes,  
ideal for preserving everyday foods



Dishwasher safe



Stackable structure



Suitable for use  
in the freezer



Valve with vacuum  
indicator



Defrost in microwave  
without lid



BPA and  
phthalate free



### Rectangular Family Containers

ACO1093 (1L) - ACO1092 (1.5L)

Ideal for vacuum-sealing lunch and dinner, these containers keep meals fresh for longer. Their rectangular shape optimizes space in the refrigerator and wherever you need them, making them perfect for everyday use, at home or on the go.

### Cylindrical Family Containers

ACO1182 (0.75L + 1.5L + 3L)

A versatile set, perfect for all your vacuum-sealing storage needs. Ideal for preserving pasta, coffee, powdered foods, and liquids, keeping their aroma and freshness intact. Includes a convenient bottle cap.





# Free Line

Freedom in the kitchen.

The revolutionary borosilicate glass and stainless steel pan that goes directly from the freezer to the oven, designed for cooking, marinating, and vacuum preserving with maximum freedom.



Made in Italy



4-in-1 solution for cooking, preserving, marinating, and sous-vide cooking



BPA and phthalate free



Suitable for use in the freezer



Dishwasher safe



Resistant to thermal shock up to 120°C



### Free pan

ACO1137 (1.2L) - ACO1138 (1.9L)

Two different sizes for versatile use. Each Free pan includes an adapter necessary for air extraction with Magic Vac vacuum sealers, and a special lever to facilitate opening the lid.

### From freezer to oven

The innovative glass pan that goes directly from the freezer to the oven, for cooking, preserving, and sous-vide cooking with maximum freedom.





# Gastronorm Line

The chef-proof steel.

Designed for professional use, they guarantee excellent performance in the preservation and quick marinating of food.



Made in Italy



Lid with co-molded silicone gasket



Double-layer stainless steel structure



Operating temperature: from -18 °C to +200 °C (without valve assembly)



Patented valve, removable and dishwasher-safe



Suitable for the quick marinating function



### Gastronorm 1/1 Containers

ACP1120 (25L) - ACP1115 (18.9L) - ACP1110 (12.7L)

Designed for professionals, these containers are ideal for storing large quantities of food. They are available in three different depths to meet every need and are equipped with a lid measuring 530 x 325 mm.

### Gastronorm 1/2 Containers

ACP1215 (8.6L) - ACP1210 (5.7L)

Available in two different depths, with a compact lid measuring 265 x 325 mm.





# Accessories

All the benefits of vacuum sealing.

The excellence of the Magic Vac system extends to the entire range of accessories, designed to offer you a wide variety of uses.



Made in Italy



Simplifies organization at home



Maximum practicality in daily use



Extend the functionalities of home vacuum sealing



Extremely versatile solutions, suitable for all uses



BPA and phthalate free



### Bottle caps

ACO1013 (2pcs)

Keep the freshness of your favorite wines longer with these practical bottle caps. They create a vacuum seal that preserves the aroma. An essential accessory for all wine lovers.

### Bag Cutter

ACO1094

Open any type of vacuum-sealed bag with a simple and quick gesture. Its precision blade ensures a clean, effortless cut, completely safely.



### Accessories for glass jars

ACO1007 – ACO1053 – ACO1054 – ACO1055

Transform ordinary glass jars into vacuum containers and preserve jams, sauces, and dressings at their best. These accessories fit standard jars (Ø 82 mm) to seal in the freshness and flavor of your homemade creations.

# SpaceOff

The ideal solution for seasonal changes.



Space-saving bags,  
resistant and reusable



Easy to use with  
any vacuum cleaner



**-80%** Reduces overall  
volume by 80%



Double hermetic seal



## SPACEOFF SPACE-SAVING BAGS

CODE	CONTENTS	PACK	EAN
ACB0002	Box with: 2 bags 45x60cm	24	8018294009465
ACB0003	Box with: 2 bags 55x90cm	24	8018294009458
ACB0004	Box with: 2 bags 80x100cm	24	8018294009441
ACB0005	Box with: 2 bags 45x60 cm 2 bags 55x90 cm 2 bags 80x100 cm 1 travel bag	12	8018294009472









[magicvac.com](http://magicvac.com)



**Flaem Nuova Spa**

Via Colli Storici 221/223/225  
25015 - Desenzano del Garda (BS) - Italy  
Tel. +39 030 9910168  
[info@gruppoflaem.it](mailto:info@gruppoflaem.it)  
[www.gruppoflaem.it](http://www.gruppoflaem.it)